

# Installation Instructions



Please Read Disclaimers:

## ***PLEASE READ ALL INSTRUCTIONS BEFORE BEGINNING INSTALLATION***

These guidelines are provided in good faith to help prevent any problems caused by common errors in installation. The manufacturer and/or distributor of this product shall not be held responsible for installation actions taken or not taken. There are many details of installation that are assumed to be general construction knowledge to experienced installers; which are not included in these instructions. These installation guidelines are intended to be strictly recommendations and are NOT to serve as a step-by-step, fail-safe installation checklist. Selection of an experienced installer is the sole responsibility of the project owner and architect. Marlite, Inc. does not accept any responsibility for job failure resulting from or associated with improper site environmental conditions.



Effective Date: 11/17/16

*This page intentionally left blank*

# GENERAL NOTE!

## NEMA LD-3 SECTION A.7

### TYPICAL PROBLEMS- CAUSES AND PREVENTION

- A. Stress cracking - Cracking of the laminate at corners and around cutouts (see Figure A-9) may be caused by improper fabrication during installation. Rough edges, inside corners that have not been radiused, and forced fits can cause cracking. Radiusing all edges and inside corners as large as possible 3 mm (1/8 in.) minimum will minimize stress cracking. A radiused corner created by a 6 mm (1/4 in.) diameter router bit is normally used.

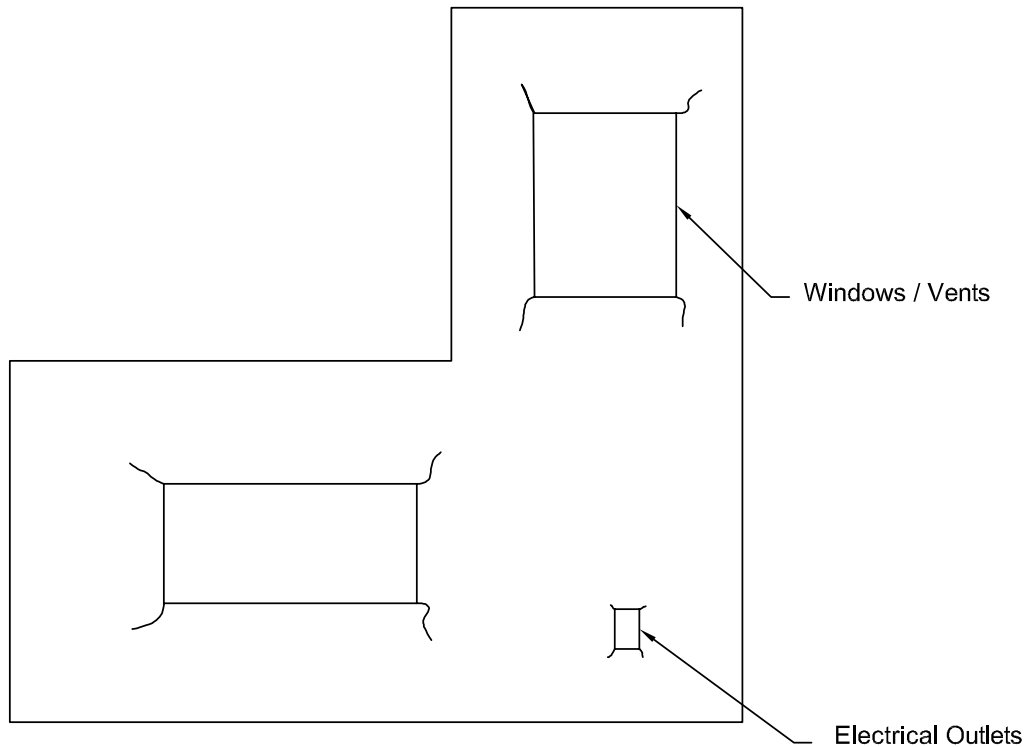
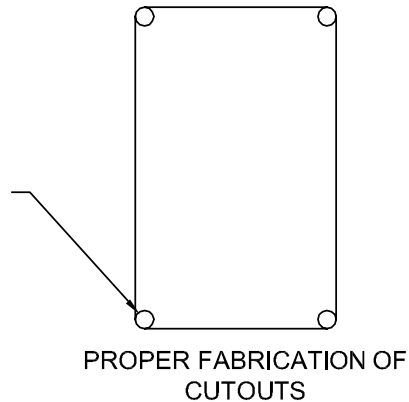

FIGURE A-9  
CRACKING OF LAMINATE

NOTE! To help prevent stress cracking of the laminate, pre-drill all four corners using a 1/4 " bit. Do not square the corners.



# High Humidity

Many Surface Systems® Panels are subject to the effects of moisture. DO NOT USE IN KITCHEN, RESTROOMS, OR OTHER HIGH HUMIDITY AREAS.

## Tools Needed:

- level
- Block plane
- Sanding block
- Drill
- Table saw or circular saw with fine-toothed carbide blade
- Chalk line
- Hack saw
- Tape measure
- File
- Miter box
- Square
- Pencil

## Caution:

Be sure to use the proper safety guards when cutting panels. Also wear safety glasses or face shields and hand protection. NOTE - Metal veneer products may produce sparks when cutting. Take proper precautions for dust removal.

## Wall Preparation

Structural walls should be finished with building completely closed. Walls must be thoroughly dry before panels are applied. Panels must be applied over a smooth, solid, flat backing such as plaster, drywall or plywood. On exterior walls, a vapor barrier should be used between backer and studs to discourage warping. Protect existing surfaces with drop cloths.

## Preparation/Handling Tips:

Open cartons and carefully inspect all panels. Due to texture and manufacturing techniques, some panels may vary in color, consistency, and pattern. Panels must be stored in a dry environment. Store panels flat and off concrete floors.

**Conditioning:** All panels shall be allowed to equalize to the moisture and temperature in the room environment prior to installation. This is accomplished by standing them around the room win which they are to be installed for at least 48 hours before application. Room temperature should be approximately 60-80°F and a humidity range of 35-55% must be maintained during storage, installation and product life cycle.

## Fabrication

Always cut panels “face up” with a fine-toothed carbide-tipped blade using a table saw or “face down” with a portable power saw using a fine-toothed carbide-tipped blade to assure a clean-cut edge. The use of a block plane, sanding block, or file will assist in minimal trimming and provide a clean edge. ALWAYS REFINISH AND SEAL TRIMMED EDGES.

Always use Surface Systems® application hardware and perimeter trim designed for the job. They are easily cut with a hack saw or power miter box.

## Adhesive Required

Marlite Brand C-109 Premium adhesive is the adhesive recommended. This adhesive is a solvent based material and local code restrictions may require substitution. Any adhesive substitution must have the manufacturer’s approval. Clean tools with naphtha or mineral spirits. Read caution label on adhesive package before use.

## Clean-up

Surface Systems® Panels are easily cleaned with a soft cloth using spray-on furniture cleaner/polish for coated surfaces and spray-on stainless steel cleaner/polish for all metal products. DO NOT SPRAY ANY LIQUIDS ON PANEL FACE OR SATURATE CLOTH WITH LIQUIDS.

Adhesive can be cleaned from the face of most Surface System Panels with mineral spirits. ALWAYS TEST THINNERS ON A PIECE OF SCRAP MATERIAL.

## Panels and Hardware

Many Surface Systems Panels are random in texture and color, this is intentional and to be expected. Care should be taken during installation to create a pleasing layout. Surface Systems panels have a vertical grain direction unless otherwise specified by the architect or designer. See page 7 of installation instructions for typical trim profiles. Finished panel sizes may vary with architect’s specification.

*Statements expressed in this technical bulletin are the recommendations for the application of Marlite® brand products as outlined and illustrated under normal conditions of installation. The recommendations provided in the bulletin represent our best judgment based on our experience with normal applications. Unless prior approval is obtained in writing from Marlite, any deviation from these recommended procedures shall be at the sole risk of the installers. Carefully inspect all panels. If a panel is defective, notify the Marlite service center nearest you at once. Failure to do so shall be at the sole risk of the installer.*

*For technical assistance, or if you have any questions regarding your order, contact;*

Marlite® - Surface Systems®, 1 Marlite Drive, Dover, OH 44622  
(330) 343-6621 E-mail: [info@marlite.com](mailto:info@marlite.com)

# Surface Systems® Adhesive - Installation Instructions

## Typical Installation

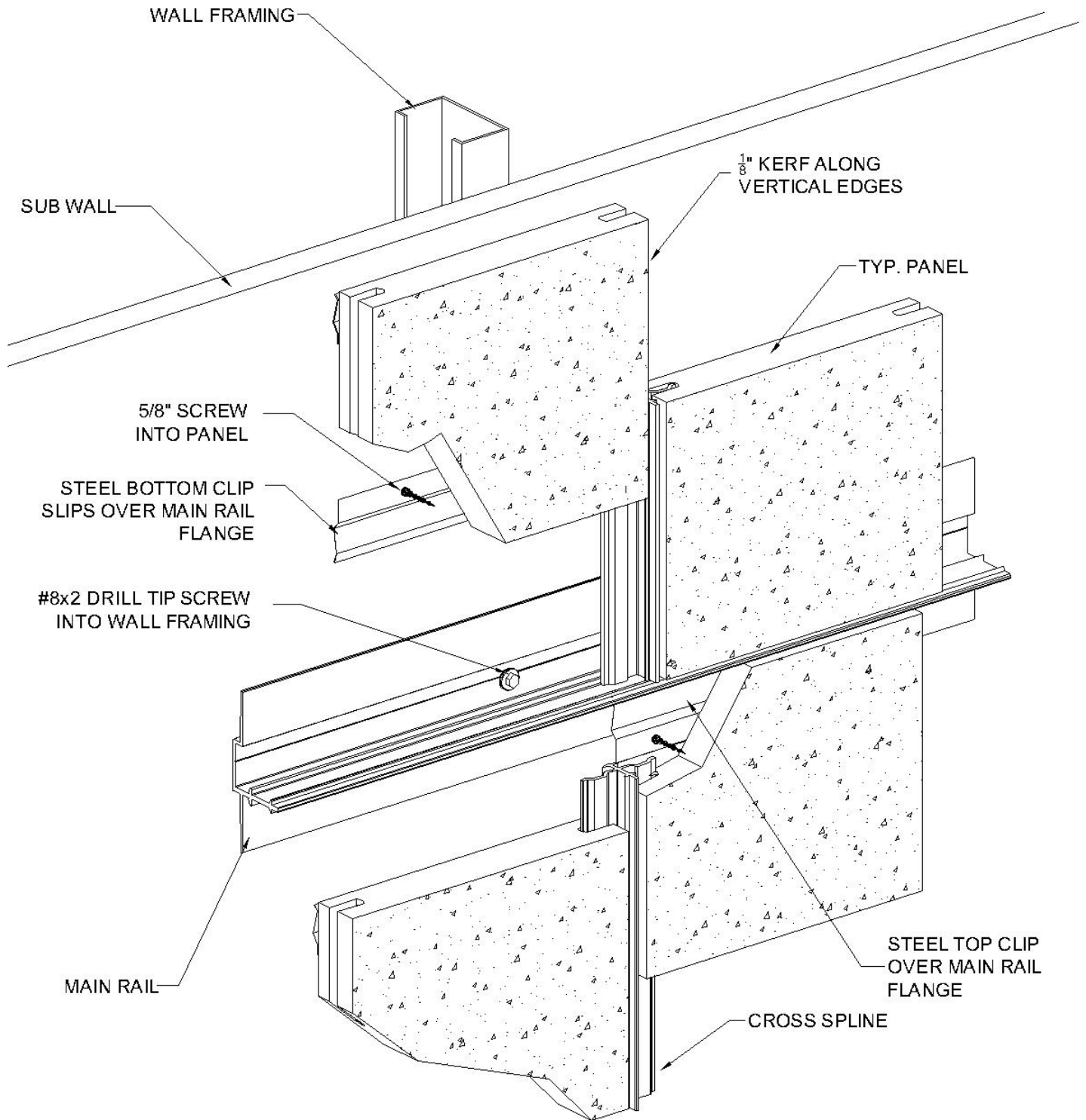

## Hidden Hardware Details

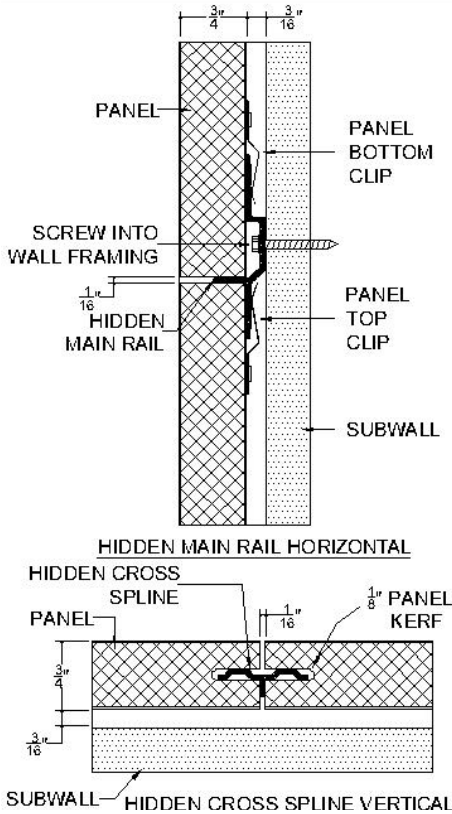

## Channel Hardware Details

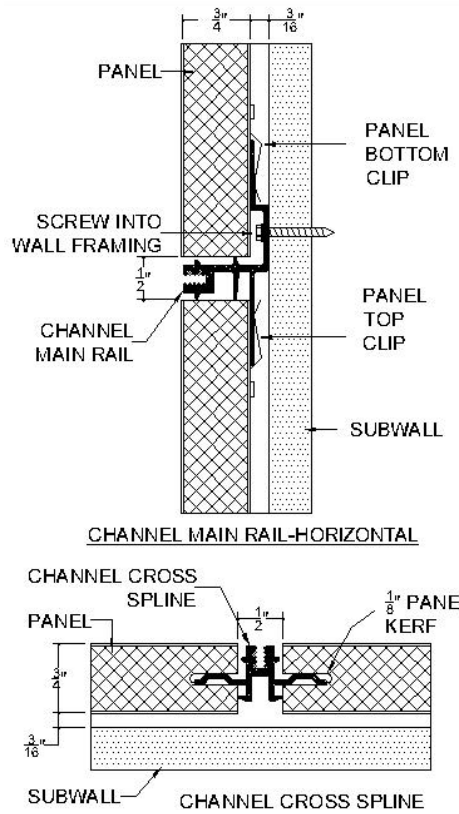

## Narrow Hardware Details

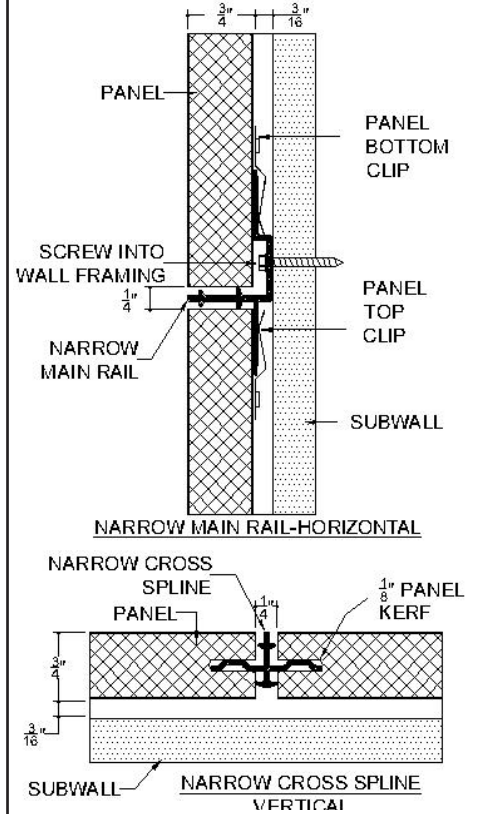

## Narrow Line Trim Details

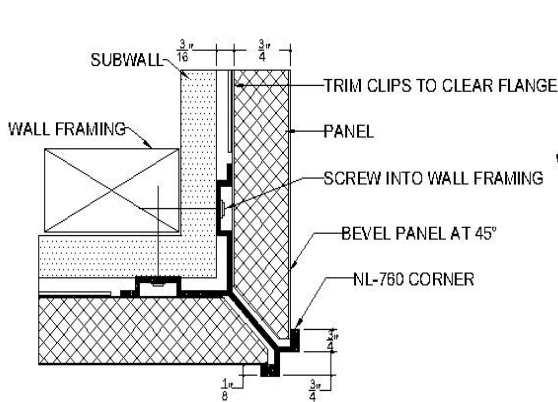

NL-760 OUTSIDE CORNER

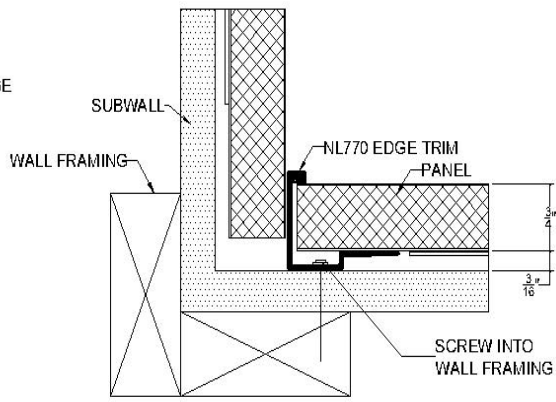

NL-770 EDGE AS INSIDE CORNER

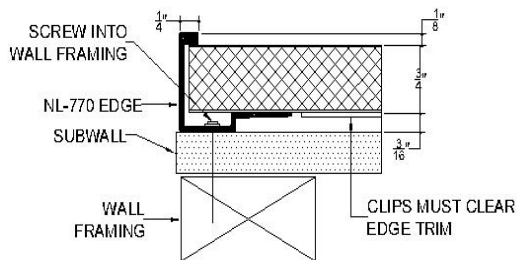

NL-770 EDGE  
VERTICAL

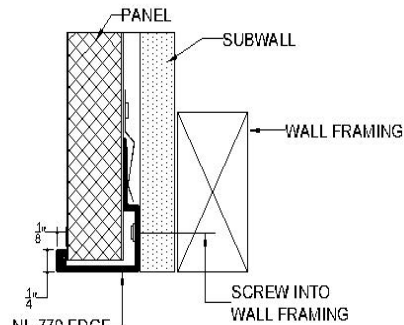

NL-770 EDGE  
HORIZONTAL



## #1 Coping Main Rail at Edge Trim

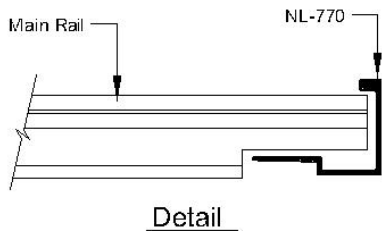
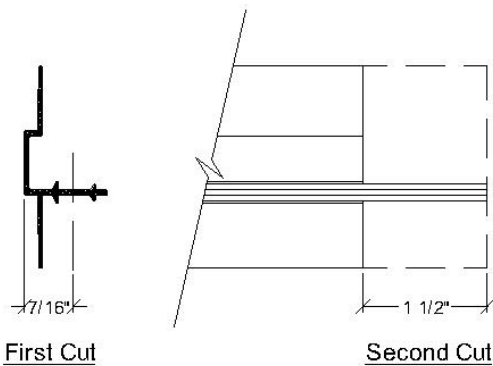
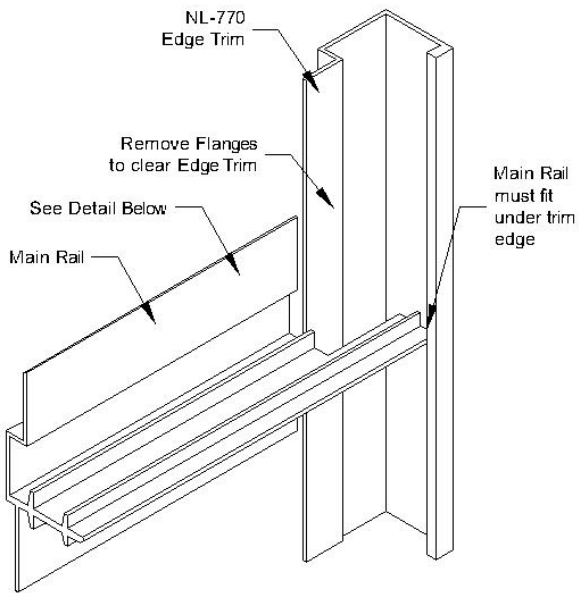

Note:  
Narrow Main Rail shown  
Channel Main Rail uses  
the same dimensions

When the Main Rail intersects a vertical Edge Trim it must have the flanges removed to clear the Edge Trim. When a table saw is available the first cut is made by setting the fence at  $7/16''$  and the blade as high as possible. Run the trim in with the back side against the fence and cut to  $1\ 1/2''$  as shown. The second cut is made by lowering the blade to  $1/2''$  and using a sliding square to remove the flanges. Note: Make sure the fence is well clear of the trim before the second cut to avoid kick back.

## #2 Coping Main Rail at Outside Corner

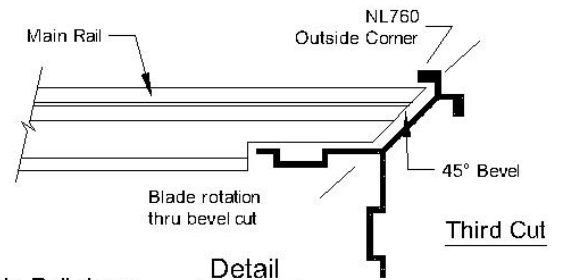
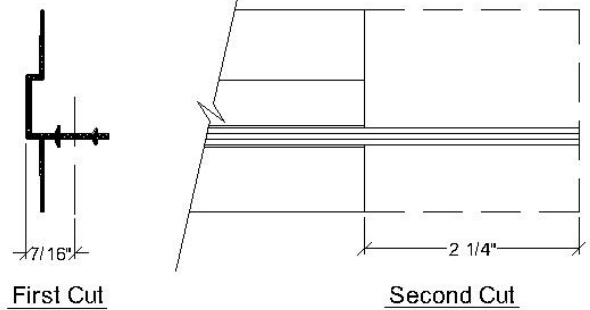
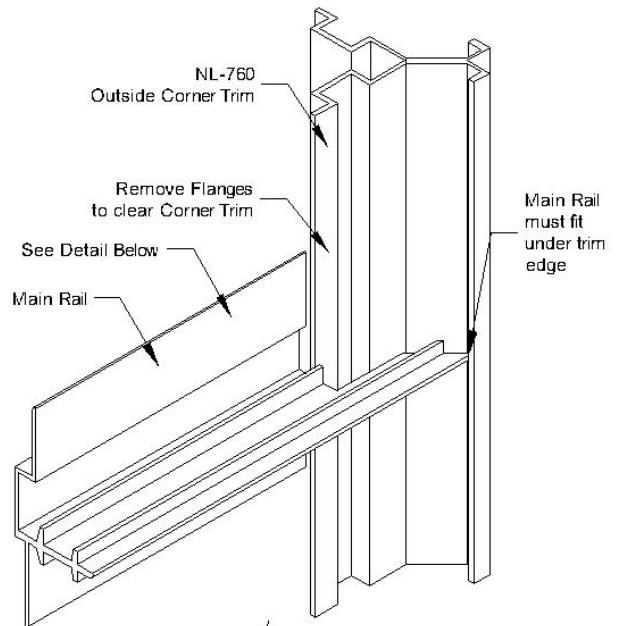

Note:  
Narrow Main Rail shown  
Channel Main Rail uses  
the same dimensions

When the Main Rail intersects an Outside Corner Trim it must have the flanges removed to clear the Outside Corner Trim. See the previous detail for instructions on flange removal, remember to remove at least  $2\ 1/4''$  of Main Rail flange, as shown. After flange removal, the  $45^\circ$  bevel can be cut by using a power miter saw. Note: Hold the Main Rail so that the back is away from the saw fence, using a block under the Main Runner if necessary. If the bevel is cut with the bottom of the Main Rail against the fence it may snag on the blade.



### #3 Installing Inside Corner Trim

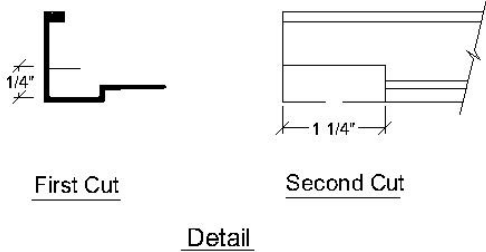
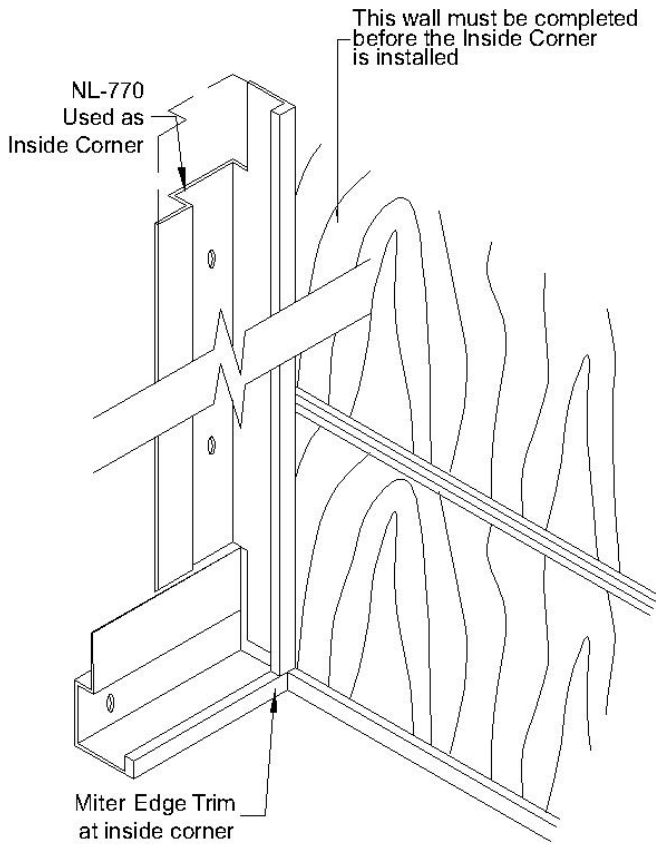

Inside Corners are installed after a wall is completed, before beginning the next wall. Cut the Inside Corner to fit between the edges then remove the flanges as shown. Make the first cut on a table saw. Make the second cut with a power miter saw. Set the trim upside down over the edge of a piece of scrap 2x4 to make this second cut easier.

*Attach the trim with the screws provided at 32" c/c max. Do not overtighten the screws as the trim will twist and distort.*

### #4 Installing Outside Corner Trim

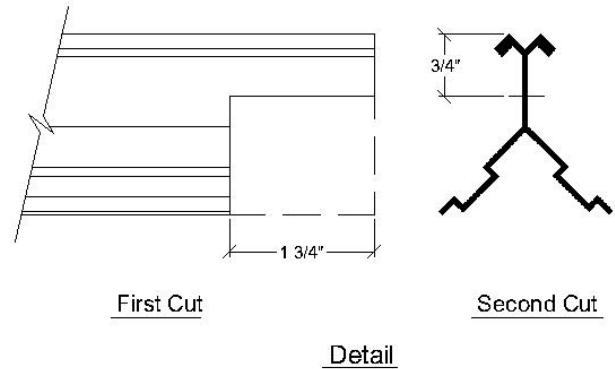
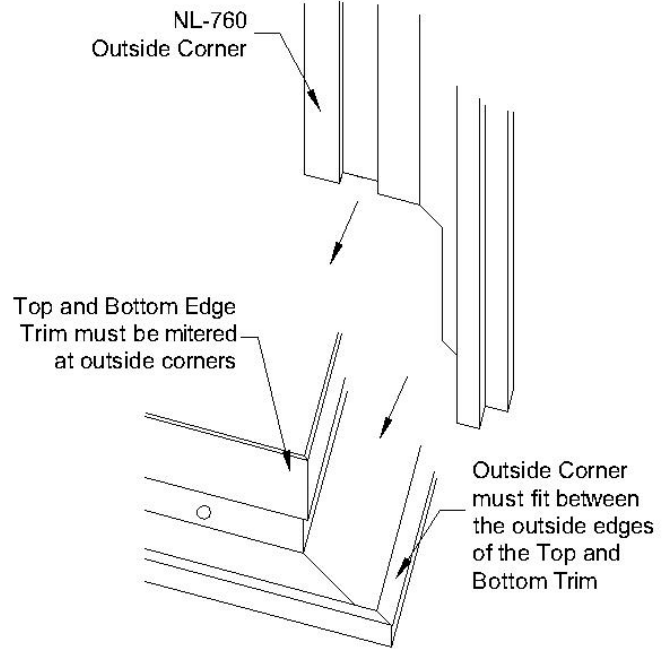

Outside Corner Trim is installed after the top and bottom Edges are in place. Cut the Outside Corner to fit between the Edges then remove the flanges as shown. Make the first cut using a power miter saw, holding the trim upside down against the fence. Make the second cut using a table saw. Be sure that the cut out section is on the outside of the blade so the scrap doesn't jam between the saw fence and blade.

*Attach the trim with the screws provided at 32" c/c max. Do not overtighten the screws as the trim will twist and distort.*

## #5 Layout

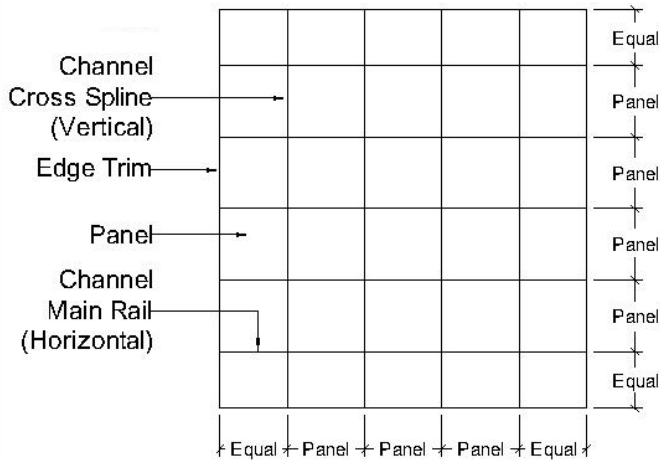

See architectural elevation to determine layout and location of panels. To pre-plan a balanced layout, top & bottom panels should be equal in height and end panels should be equal in width (See illustration). Before installation begins it may be necessary to arrange panels on the floor to determine the best combination of color & pattern. ALWAYS VERIFY ANY VARIATION IN PANEL LAYOUT, NOT INDICATED ON DRAWINGS, WITH ARCHITECT OR DESIGNER.

## #6 Beginning Installation

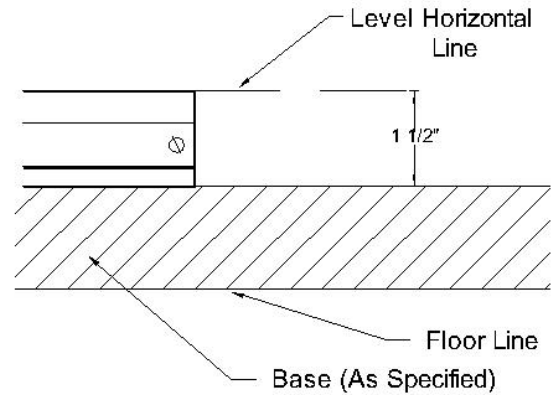

Strike a level line 1 1/2" from the bottom of the installation. This will indicate the height of the top of the Edge Trim flange. Install the bottom Edge Trim (drawings #1-4). It is important that this trim be level and straight as any inaccuracy may cause alignment problems later in the installation.

## #7 Perimeter Trim

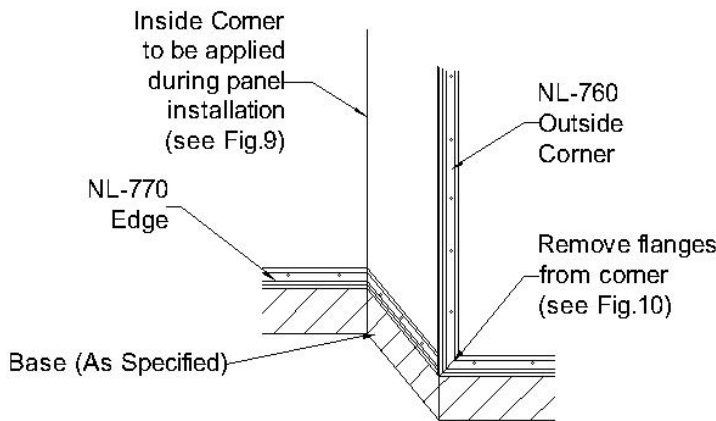

Attach all perimeter trim, this may include vertical and top Edge Trim or Outside Corner Trim. Miter cut the top and bottom trim at corners to create a neat installation (drawing #4). Inside corners are installed after a wall is completed, before beginning the next wall.(drawing #3)

## #8 Installing First Panel

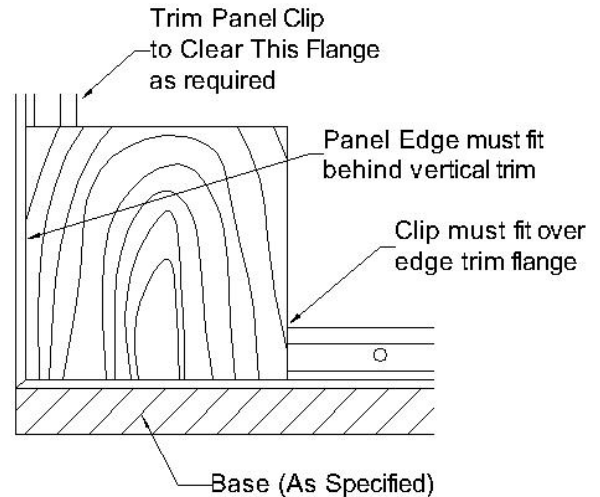

Note the panel clips on the back of the panels. The top of the panel has the clip flush with the edge. The bottom of the panel has the clip raised 3/4" from the edge. The vertical edges have kerfs (see Typical Installation). Beginning at either end, measure and field cut the first panel as required by the layout. This may require repositioning of the bottom clip and trimming both clips to clear the flange of any adjacent vertical trim. If field trimming is required, reattach the bottom clip precisely 3/4" from the bottom edge using the original screws. Inside corners are installed after each wall is completed (drawing #3). Outside comers will require the edge along the outside corner to be back cut with a 45° bevel and the clip to be cut back (see Narrow Line Trim Details).

## #9 Install Cross Splines & Panels

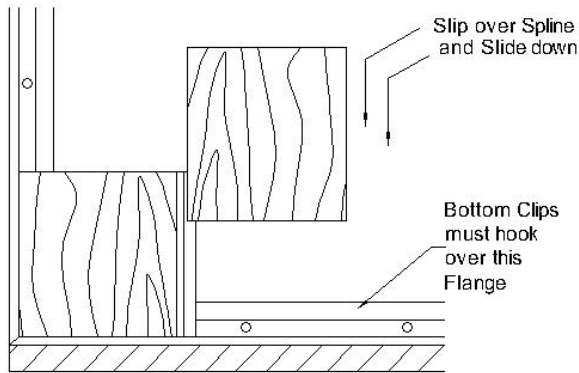

Measure and cut the Cross Spline to match the height of the first panel. Insert the Cross Spline into the panel kerf, take care to install Splines with the correct side facing outward (see Hardware Details). Place the next panel by slipping the kerf over the Spline and sliding down until fully seated. Continue installing the bottom row of panels in the same manner, making sure the top edges are aligned and level.

## #10 Install Main Rails

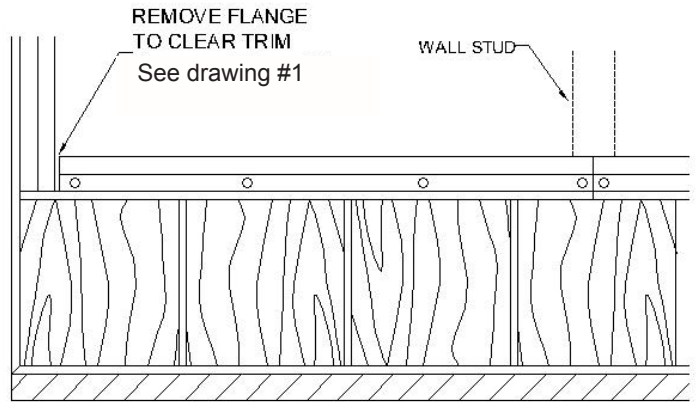

Remove enough of the flange from the Main Rail to clear any corner or edge trim (drawings #1 & 2), then cut to a length that will end at the center of a wall stud and allow attachment of the next Main Rail. Slip the bottom edge of the Main Rail into the panel top clips until fully seated. Attach the Main Rail to wall studs at 24" o/c max. using the 2" drill-tipped screws provided. It is important that this hardware be level and straight as any inaccuracy may cause problems later in the installation. Continue attaching the Main Rails along the top of the first row of panels taking care to be sure that they are straight level and fully seated. Inside corners will require the Main Rail to be miter cut for a neat installation.

## #11 Last Panel - One Row From Top

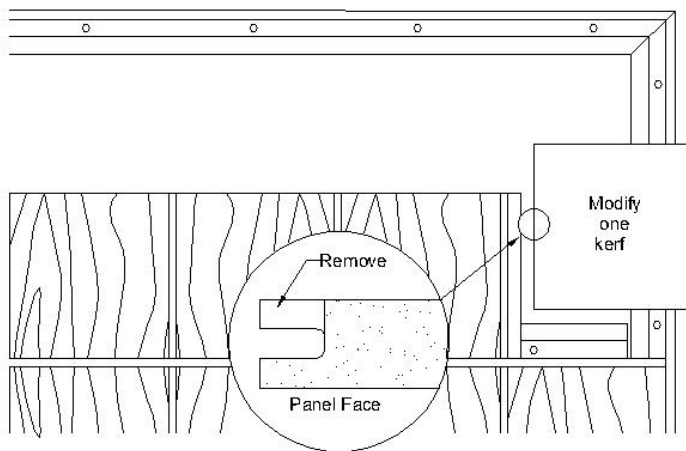

Continue panel installation up until the last panel in the first row down from the top. The last panel in this row may require special fabrication. If there is not room to slide the last panel down into place at this location it will be necessary to remove the back of the kerf on the last panel. This is easily done on a table saw and is only necessary if the ceiling interferes.

## #12 Install the Top Row

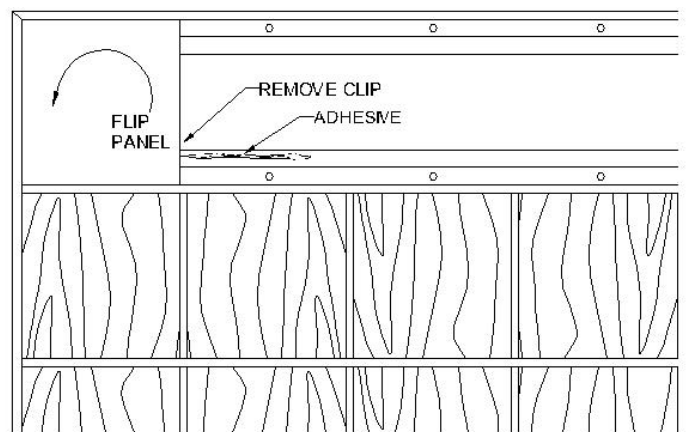

The top row of panels will be rotated so that the bottom clip (the clip that is 3/4" from the panel edge) is on top and will slip over the Edge Trim flange, the extra clip is removed and discarded. If your installation calls for matched panels that cannot be rotated then the top clip should simply be repositioned down 3/4" from its original location and the extra clip discarded. Measure and cut the first panel for the top row as required, beginning at either end of the run. Apply a liberal bead of adhesive on the flange of the Main Rail for final attachment of each panel in the top row as fit is installed. Slip the first panel into place taking care that the clip fits behind the Edge Trim flange and the vertical edge is trapped by the adjacent vertical trim. Press into the adhesive.

## #13 Install Corner Panel of Top Row

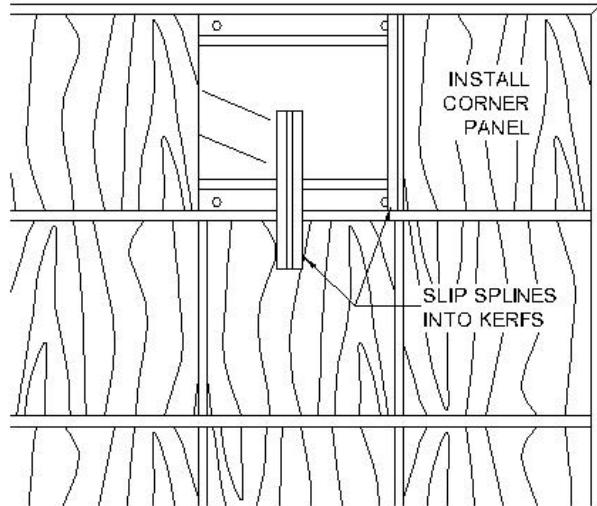

Measure and fit the last corner panel. Take care that the vertical edge of the panel is trapped by the adjacent vertical trim. Remember to allow space for the last panel to be installed. Apply a liberal bead of adhesive on the flange of the Main Rail and install the corner panel. Slip both Cross Splines into the open kerfs.

## #14 Install Last Panel of Top Row

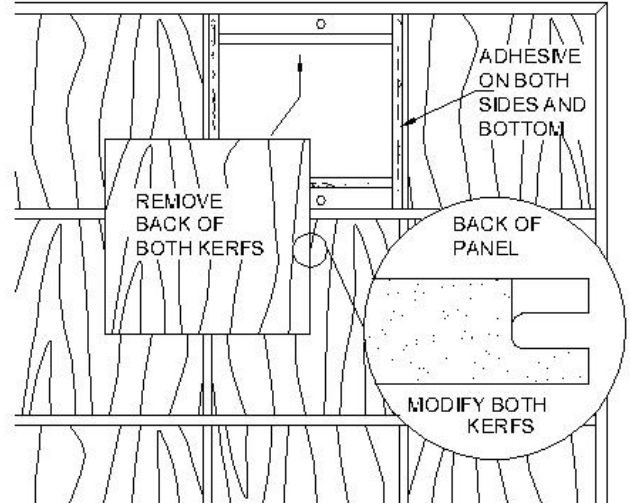

Use the adhesive to glue the splines into both of the panels adjacent to the last panel to be installed. Remove the back half of the vertical kerfs on the last panel and dry fit. Apply a liberal bead of adhesive to the exposed Cross Spline flanges and Main Rail flange. Slip the clip onto the Edge Trim flange along the top edge and press into the adhesive until fully seated.

## #15 Inside Corner Detail

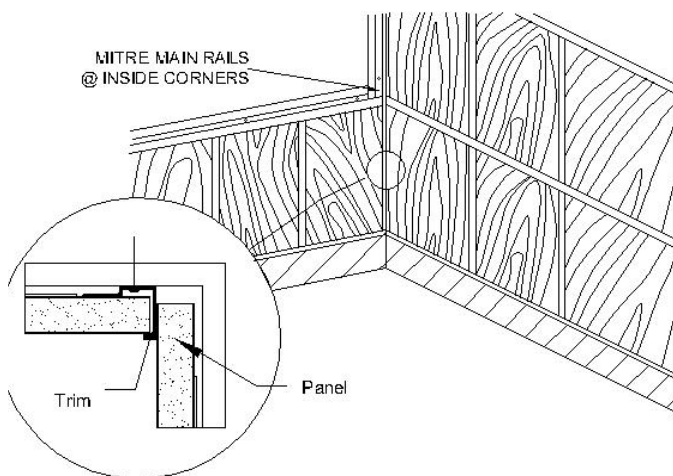

The inside corner trim will be installed after all the panels have been installed on the adjacent wall and before continuing the installation of panels on the next wall. Cut the inside corner to fit between the top and bottom trim. See detail 8 for notching.

## #16 Outside Corner Detail

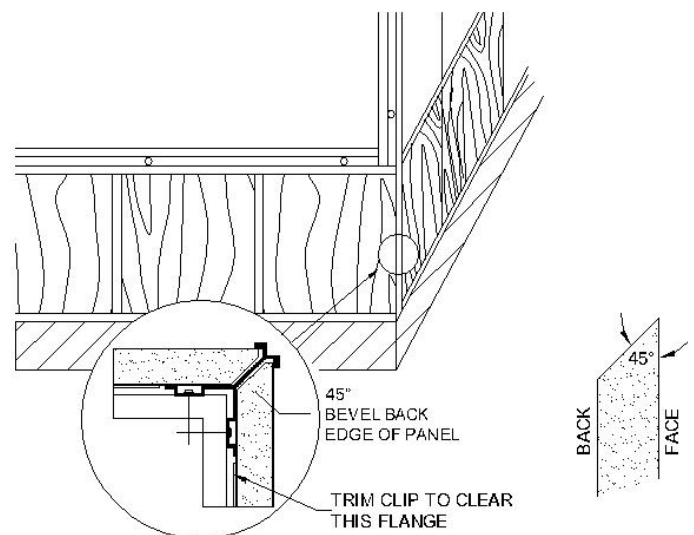

Outside corners will require the panels to be beveled to fit the trim profile. Bevel the edge at 45° as shown above. The panel clips will also need to be trimmed to clear the corner trim flange.

*This page intentionally left blank*



1 Marlite Drive, Dover, OH  
44622

1-800-377-1221  
[info@marlite.com](mailto:info@marlite.com)